

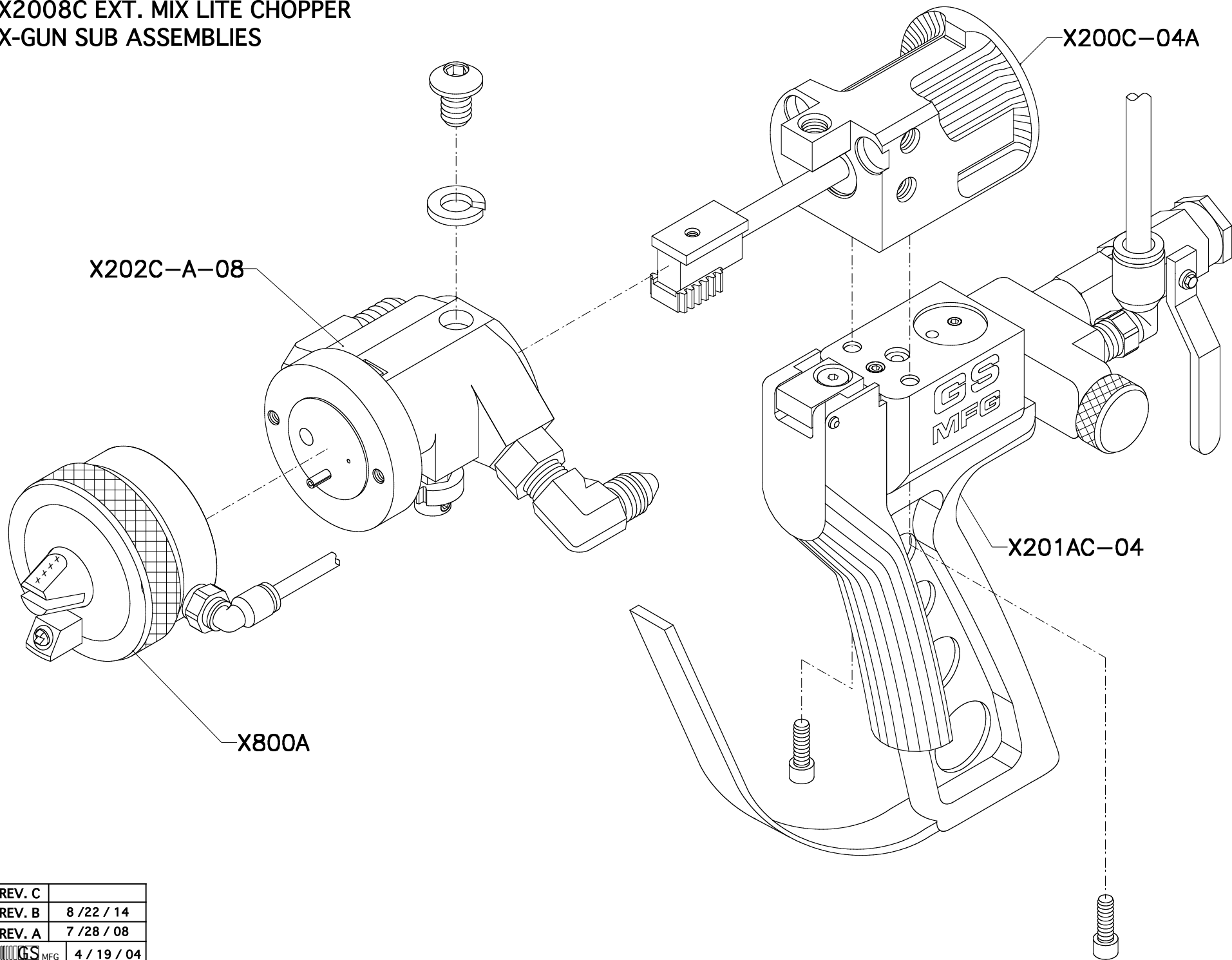

**X2008C EXT. MIX LITE CHOPPER  
X-GUN SUB ASSEMBLIES**



REV. C	
REV. B	8 / 22 / 14
REV. A	7 / 28 / 08
 GS MFG	4 / 19 / 04

# X800A RESIN HEAD ASSEMBLY

REPAIR KIT : X800RK

(\*)- INDICATES PARTS INCLUDED IN THE KIT

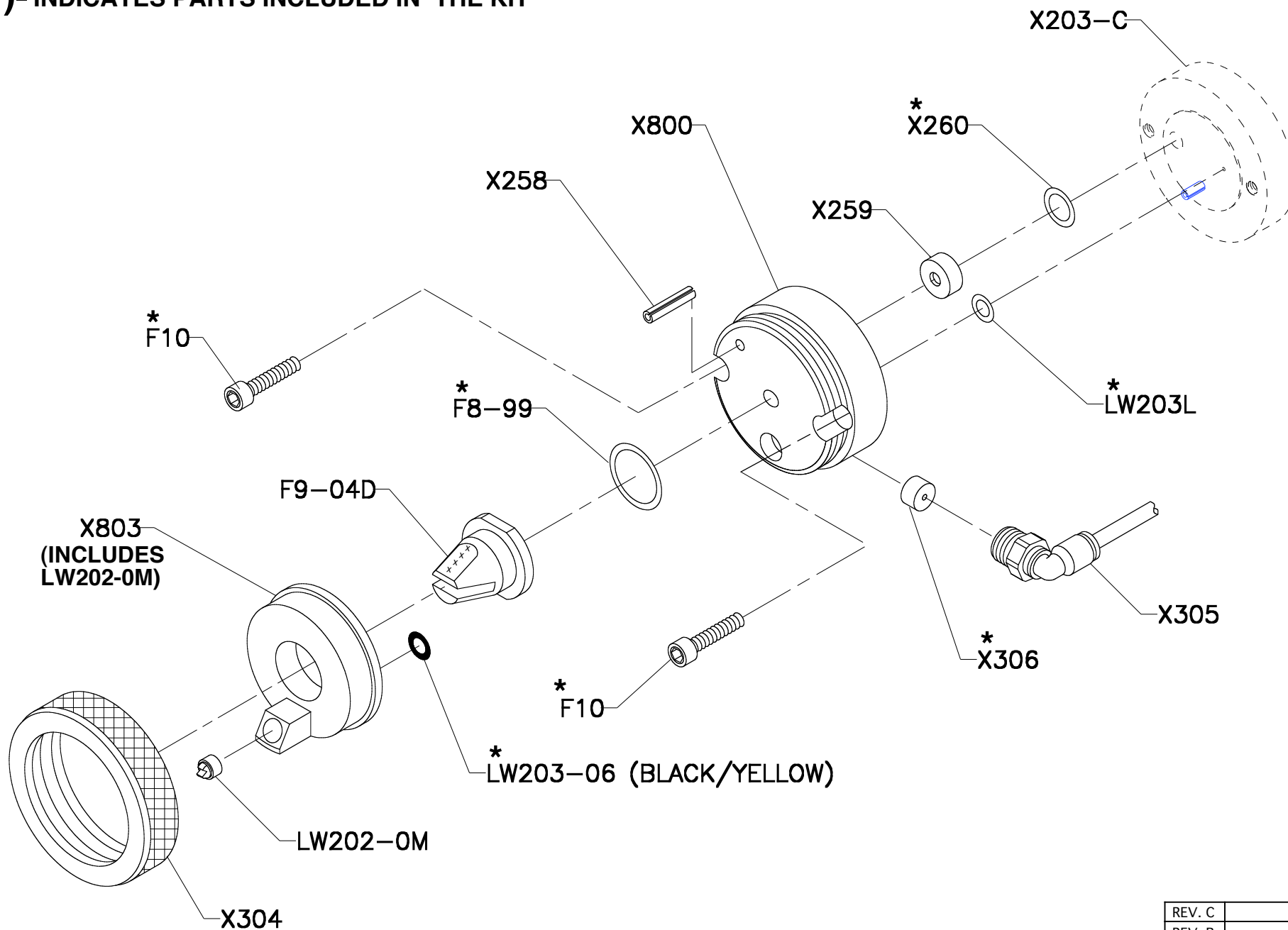

REV. C	
REV. B	
REV. A	7 / 31 / 08
GS MFG	7 / 25 / 07

# X202C-08 FLUID SECTION ASSEMBLY

\* : X254 KIT INCLUDES 6 PIECES (2 REQ'D)  
 \*\* : X252 KIT INCLUDES 5 PIECES (2 REQ'D)  
 COMPLETE REBUILD KIT: X202-RK.

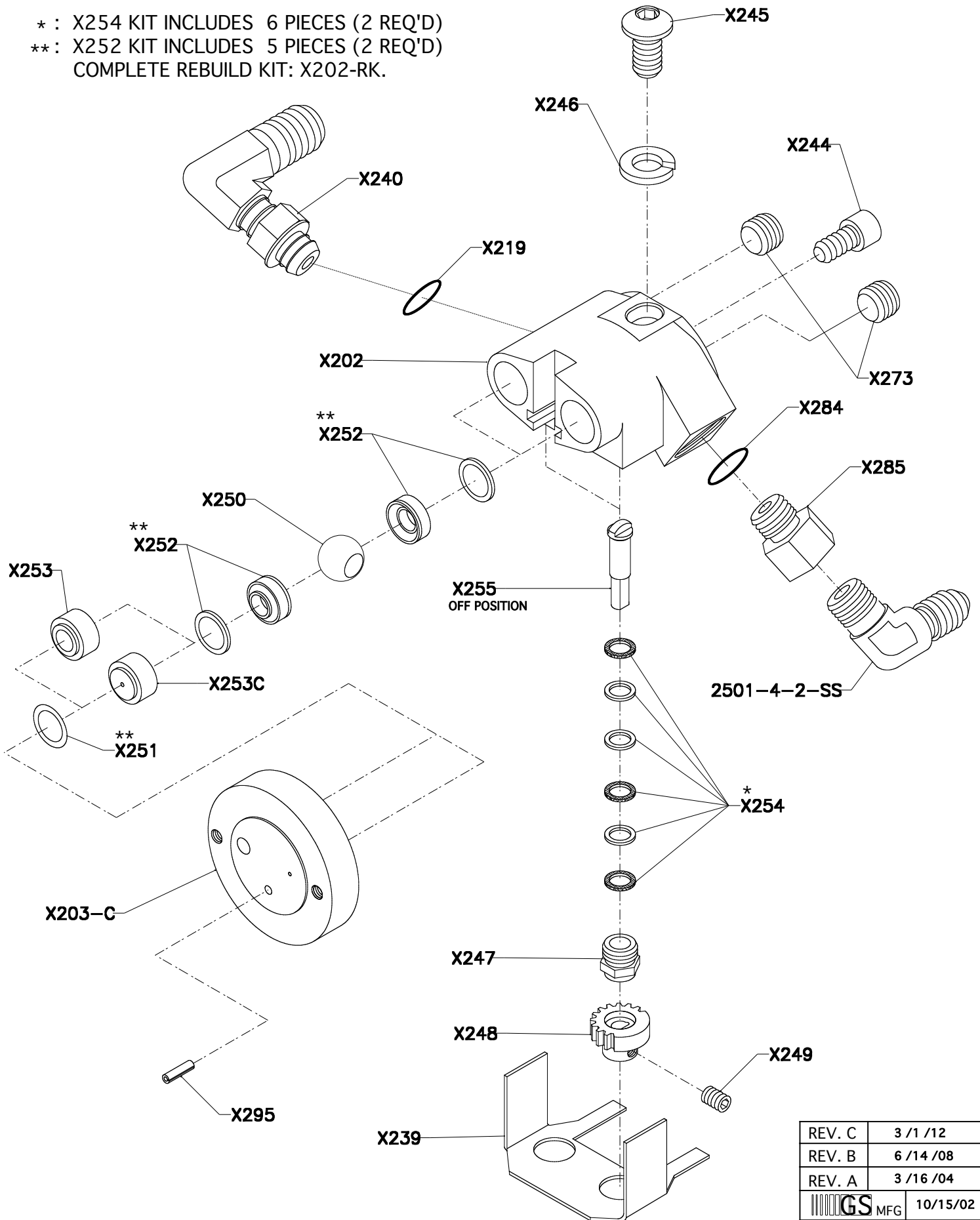



REV. C	3 /1 /12
REV. B	6 /14 /08
REV. A	3 /16 /04
GS MFG	10/15/02

# X200AC-04 LITE CYLINDER ASSEMBLY

REBUILD KIT : X200-RK

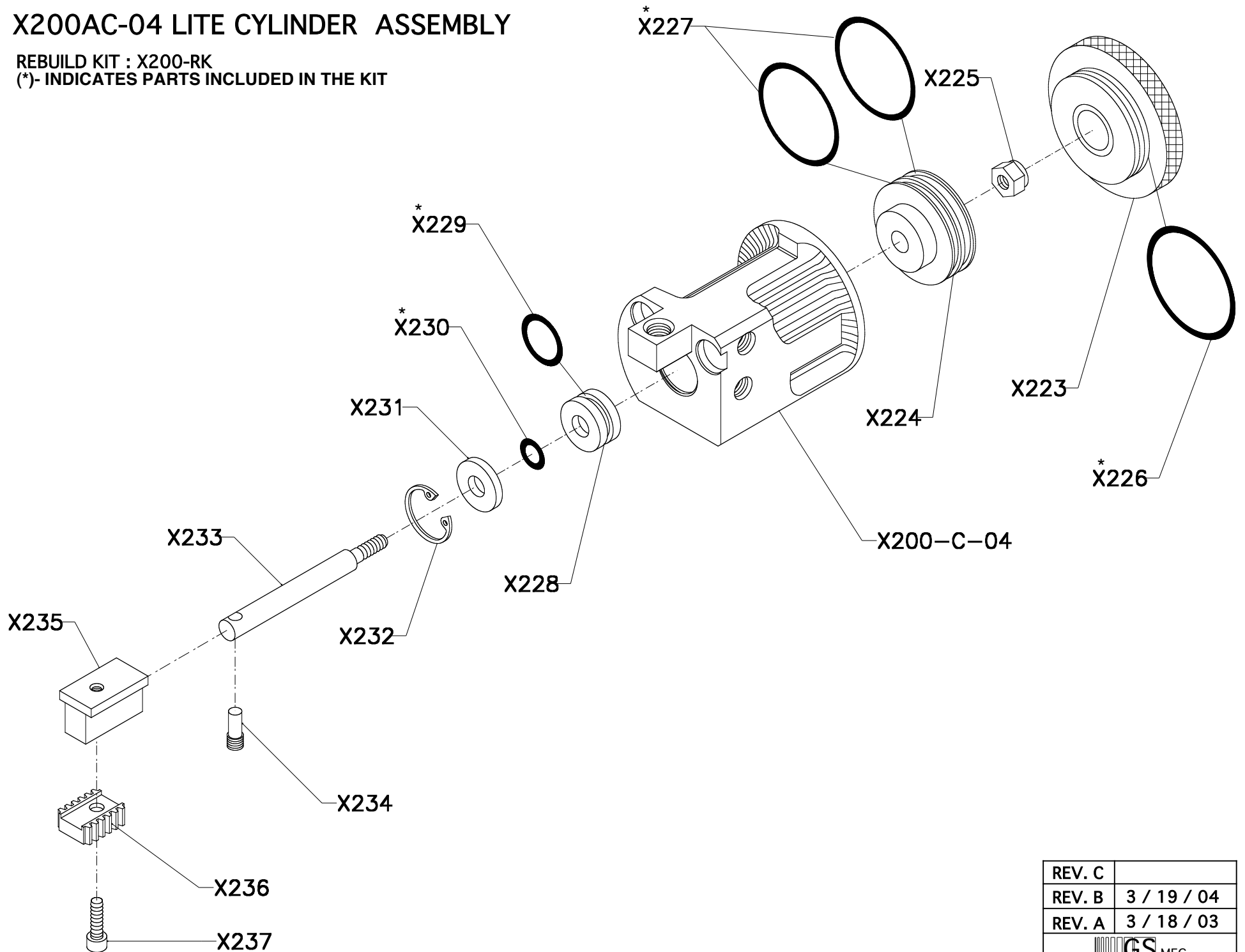
(\*)- INDICATES PARTS INCLUDED IN THE KIT



REV. C	
REV. B	3 / 19 / 04
REV. A	3 / 18 / 03
	

# X201AC-04 HANDLE / TRIGGER ASSEMBLY ( CHOPPER )

REBUILD KIT : X201C-RK

\*: INDICATES PARTS INCLUDED IN THE KIT

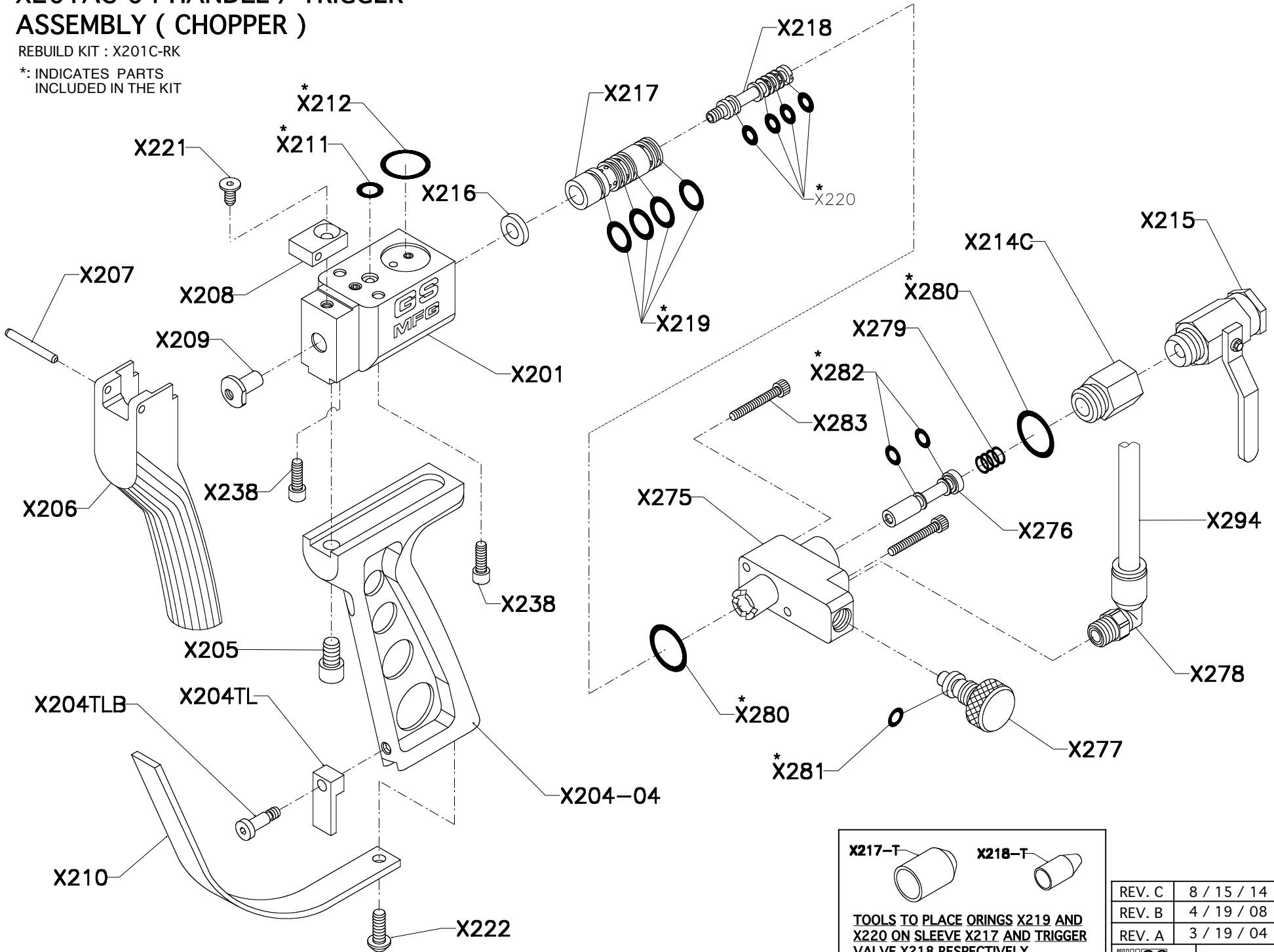

**X217-T**      **X218-T**

**TOOLS TO PLACE ORINGS X219 AND X220 ON SLEEVE X217 AND TRIGGER VALVE X218 RESPECTIVELY**

REV. C	8 / 15 / 14
REV. B	4 / 19 / 08
REV. A	3 / 19 / 04
<b>GS</b> MFG	5/30 / 03

## ALIGNMENT OF X202 FLUID SECTION ASSEMBLY TO X200 CYLINDER ASSEMBLY

1. BE SURE THAT X249(\*) SET SCREW IS TIGHTENED TO THE FLAT ON X255 STEM AND FACING OUTWARDS.
2. IF THIS IS DONE CORRECTLY, THE BALLS WILL BE IN THE OFF POSITION. THE TIMING OF THE GEARS IS VERY IMPORTANT SO THAT THE X236 RACK WILL SLIDE INTO POSITION AS SHOWN IN FIG. 2.

3. ATTACH X200 CYLINDER ASSY. TO X202 ASSY. LEAVING THE X245(\*) BOLT LOOSE. MAKE SURE X233 SHAFT IS PUSHED ALL THE WAY FORWARD.
4. INSERT X236 RACK ONTO X235 T-NUT ALIGNED WITH X248 GEARS AS SHOWN IN FIG. 2.
5. AFTER X236 RACK IS SEATED ONTO X235 T-NUT TIGHTEN X237(\*) AND X245(\*) BOLTS.

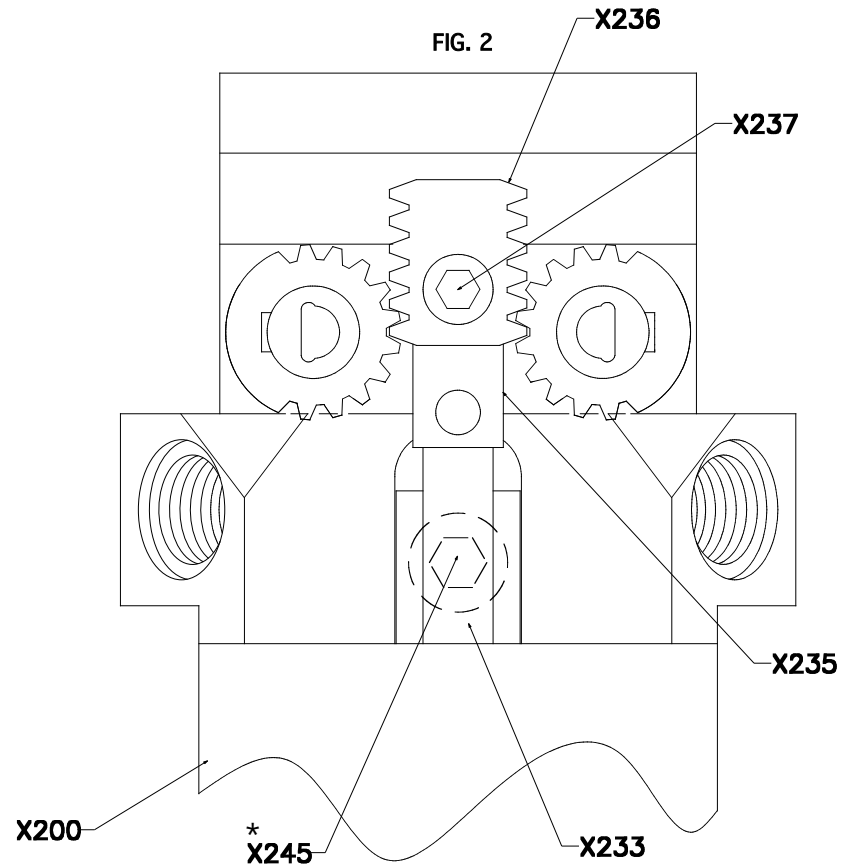
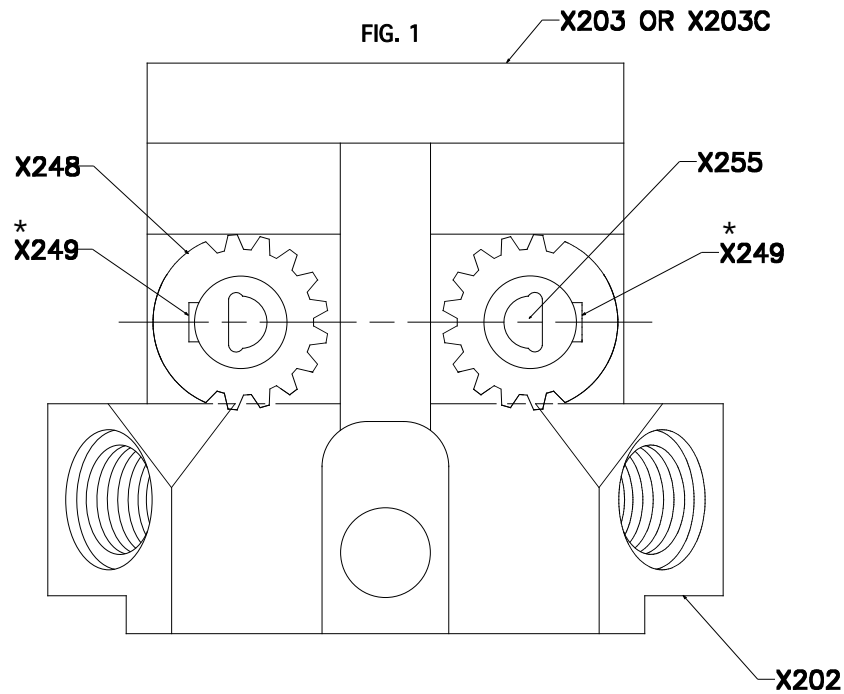

**NOTE; \* :USE BLUE LOCTITE 242  
ON THE THREADS**

REV. C	
REV. B	7 / 30 / 15
REV. A	2 / 16 / 06
 MFG	12/21/04

**X-GUN EXT.MIX CHOPPER X-GUN  
HOSES AND HARDWARE**

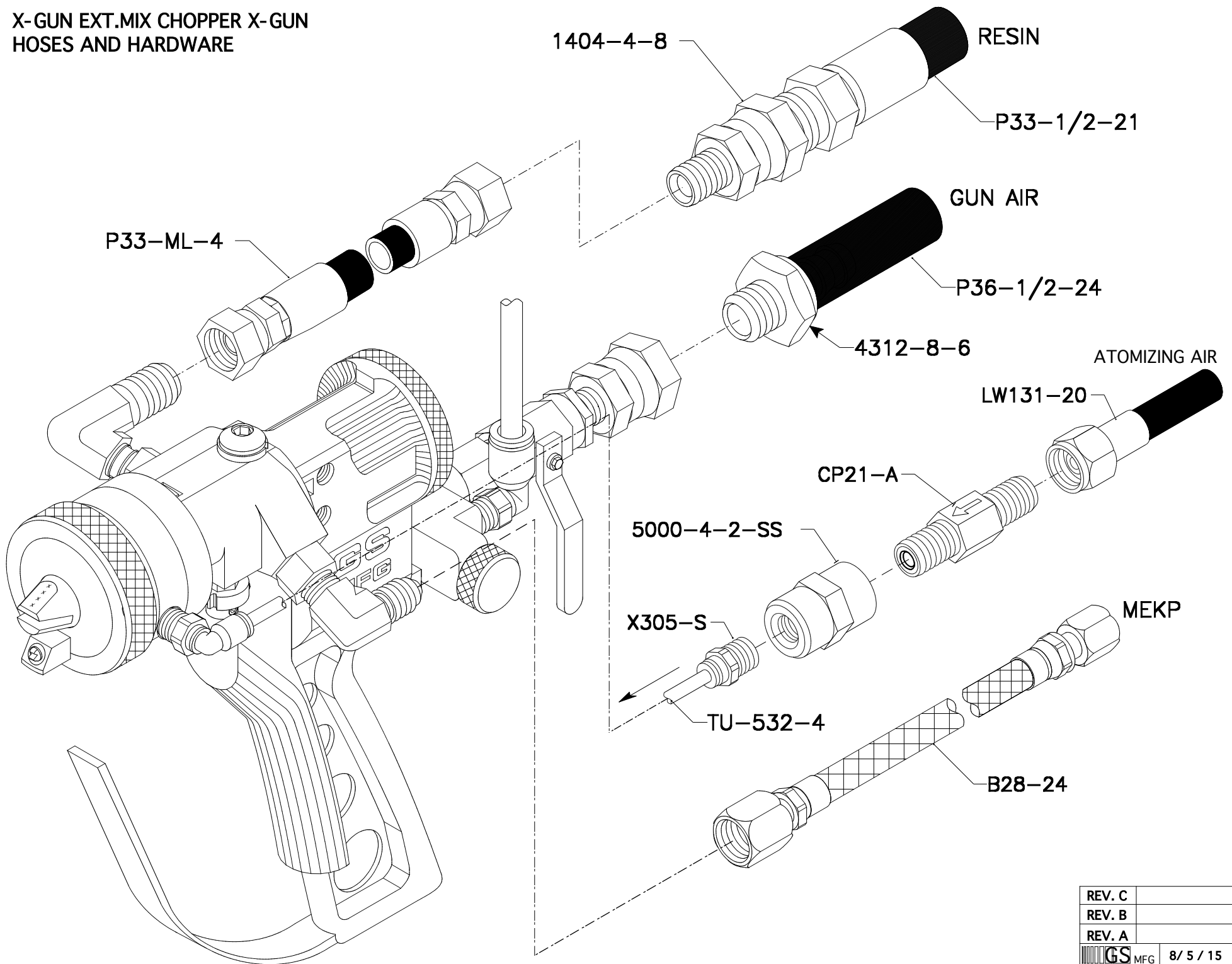

REV. C	
REV. B	
REV. A	
 MFG	8/ 5 / 15

# RC100SF-04 LITE- CHOPPER MOTOR

\*: RC100SF-RK

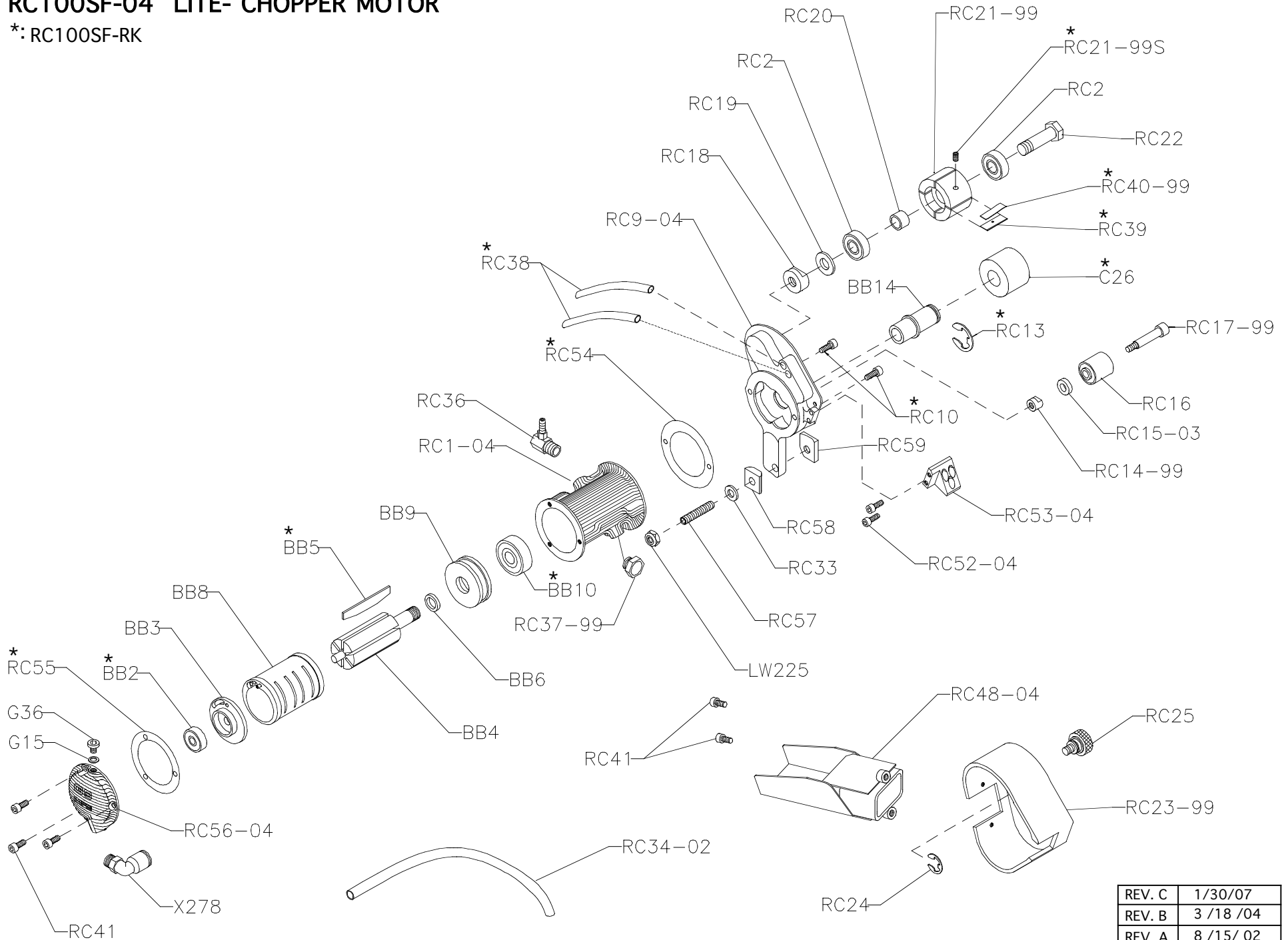

REV. C	1/30/07
REV. B	3/18/04
REV. A	8/15/02





# S1000-160-04

REBUILD KITS:

\*S10097-RK - PUMP

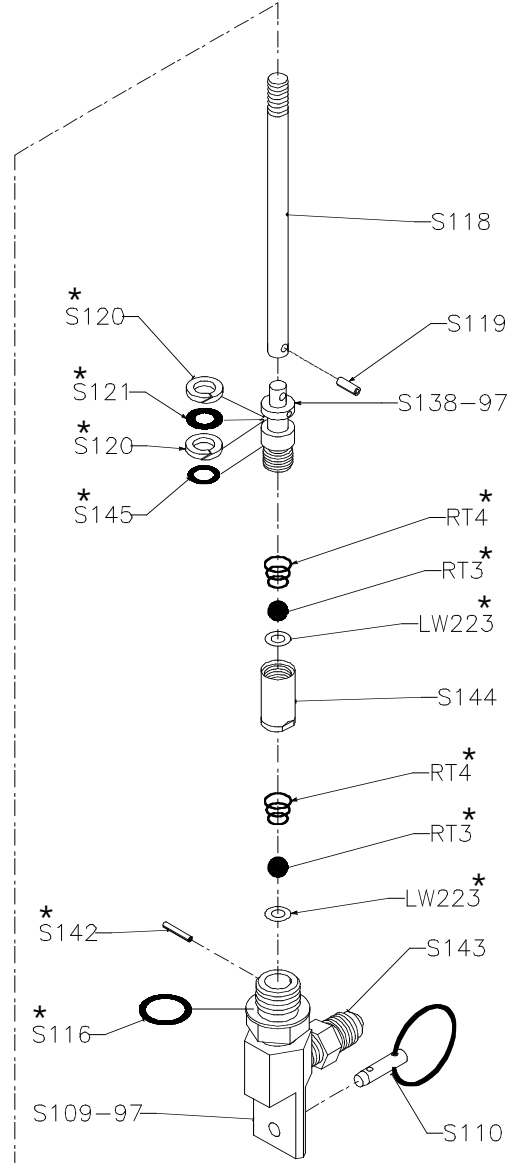
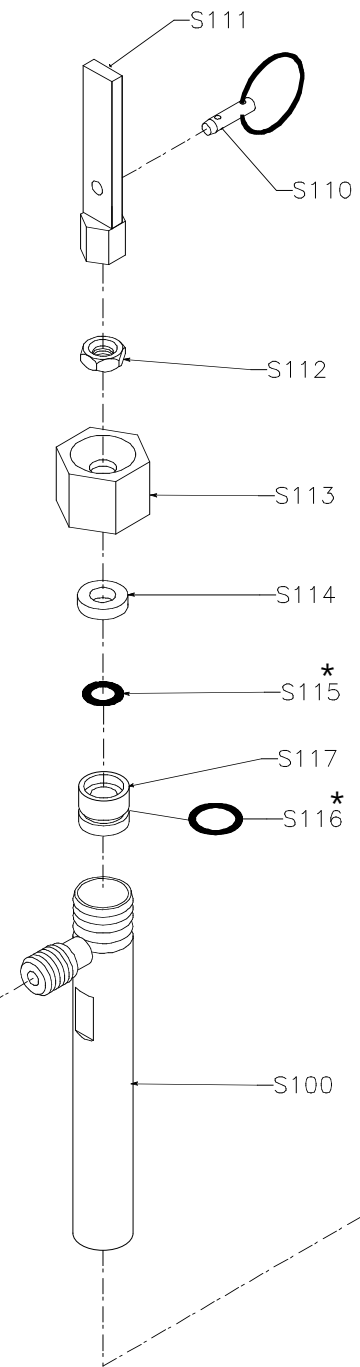
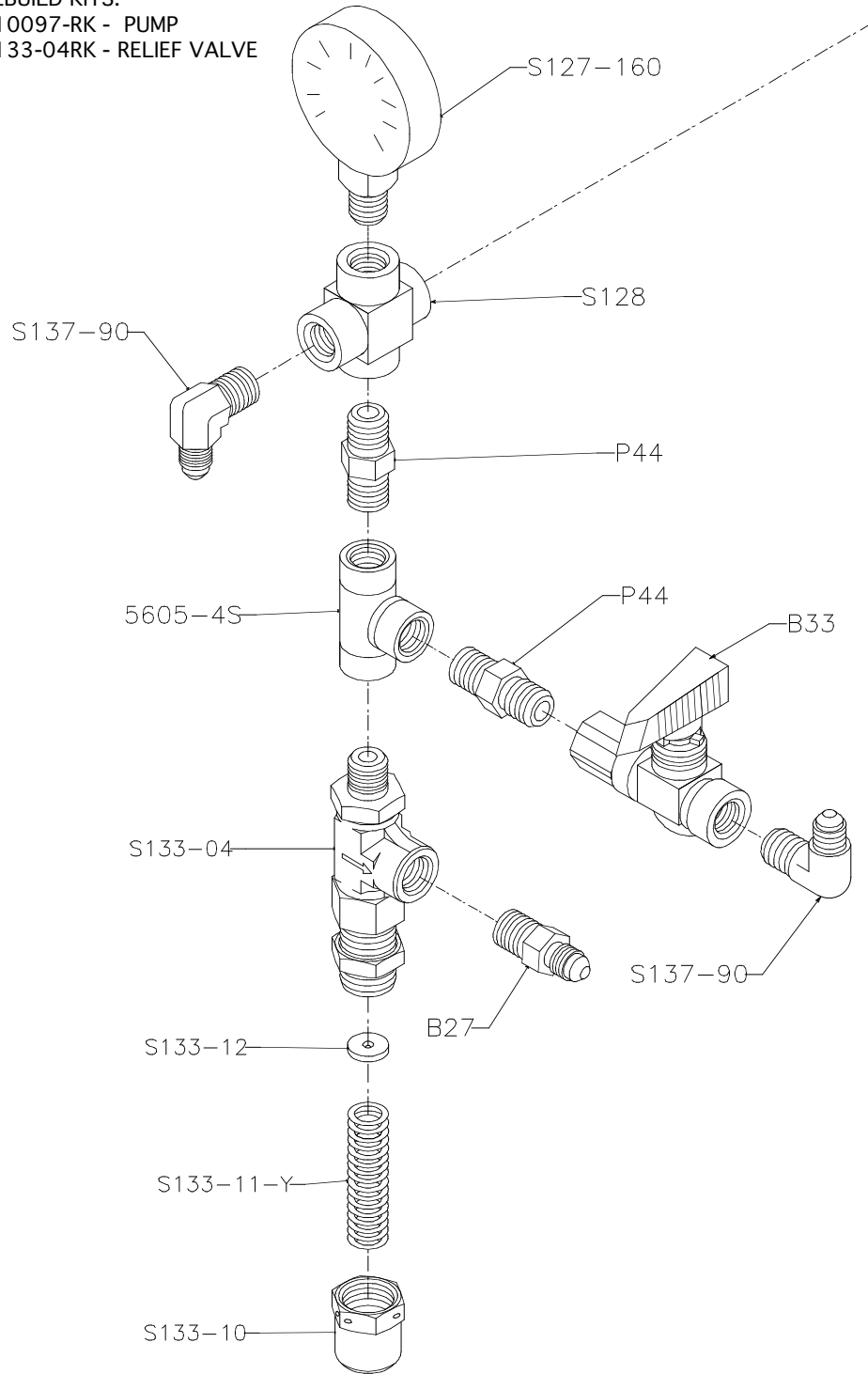
S133-04RK - RELIEF VALVE



REV. C	10 / 20 / 09
REV. B	9 / 24 / 08
REV. A	2 / 6 / 07
 MFG	8 / 3 / 04

# S133-04 RELIEF VALVE

\* REBUILD KIT: S133-RK-04

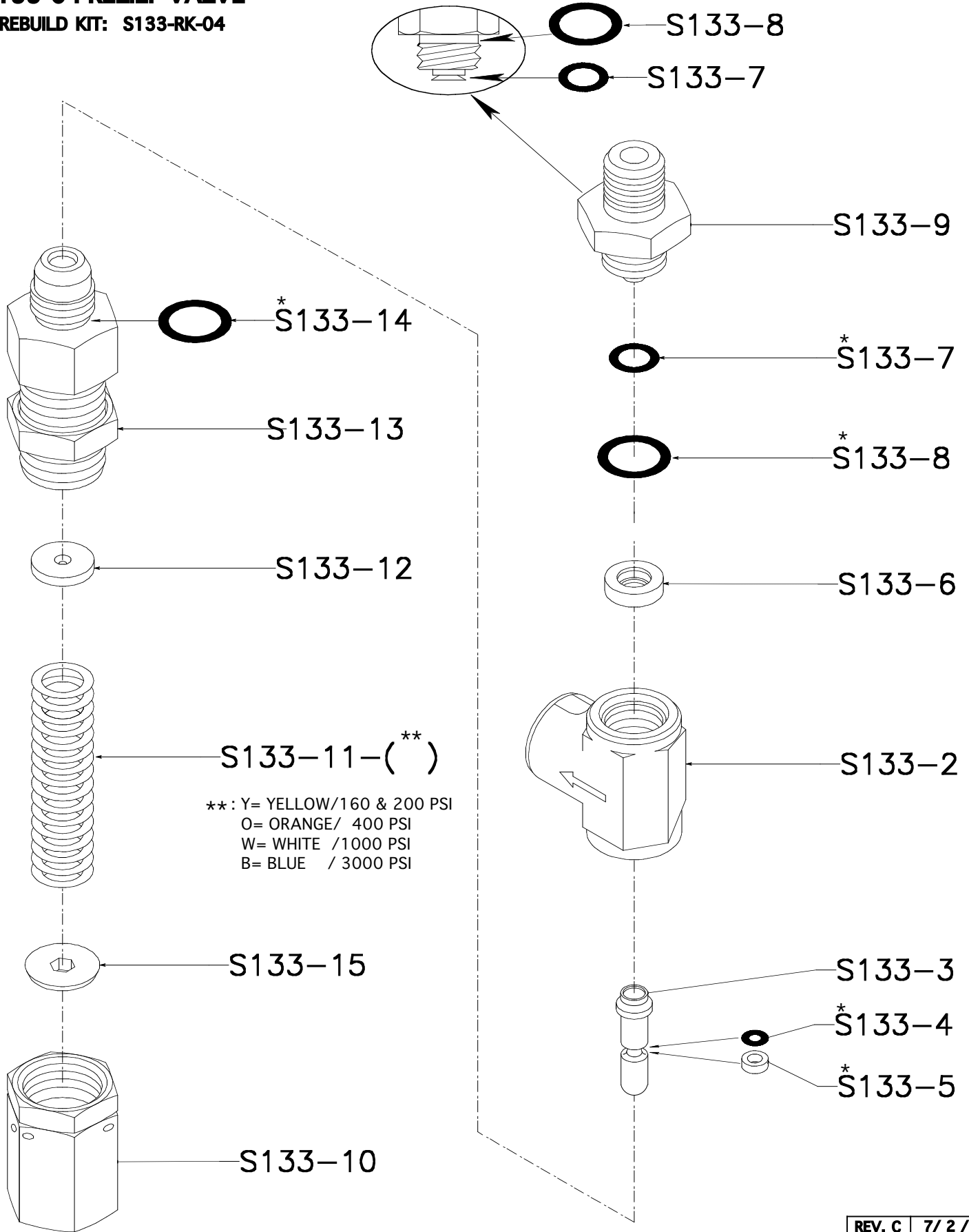

REV. C	7/ 2 / 09
REV. B	10/8/ 08
REV. A	5/ 5 / 08
GS MFG	8 /3 /04

# MEKP SIPHON HOSES / BOTTLES

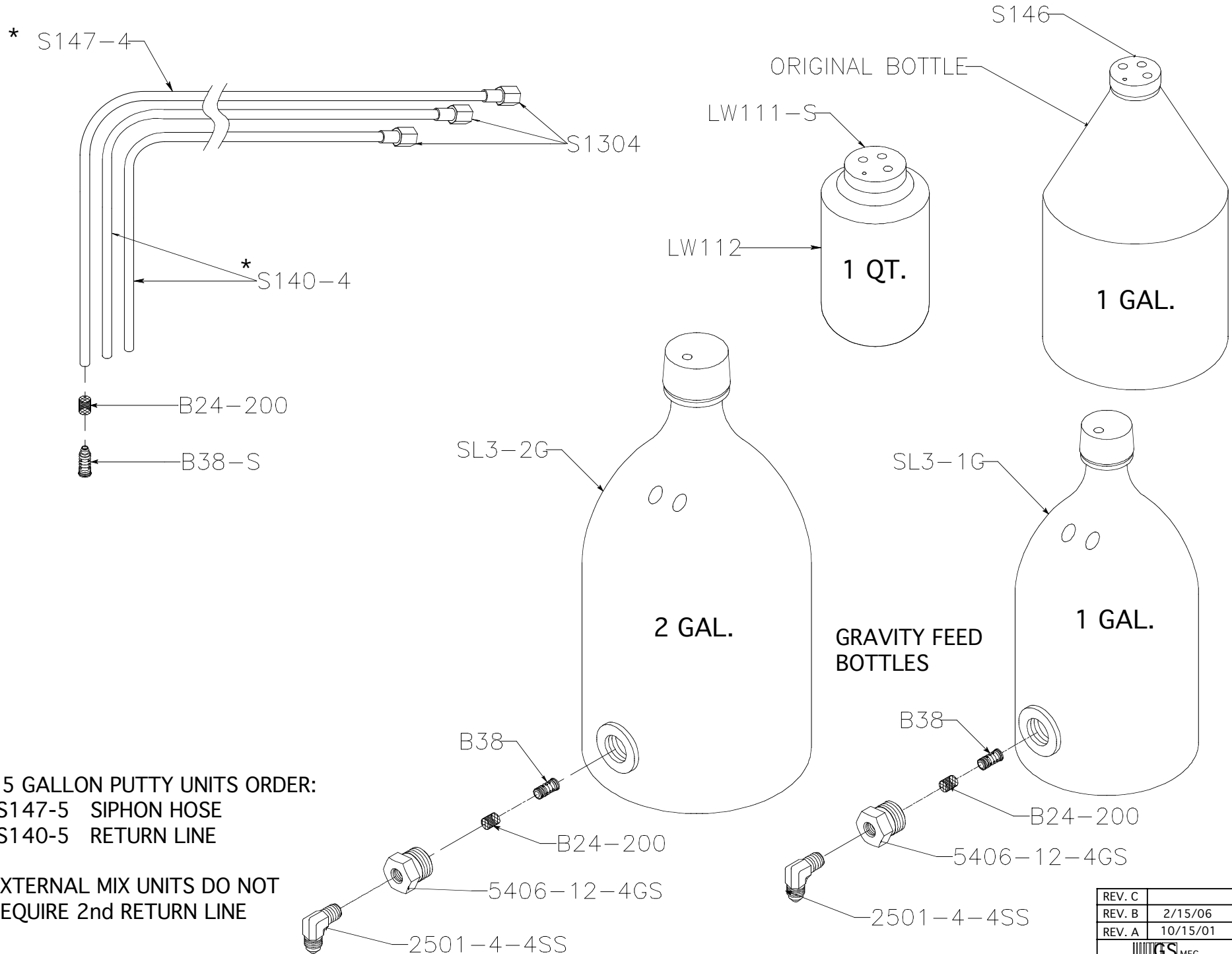



\*. 55 GALLON PUTTY UNITS ORDER:  
 -S147-5 SIPHON HOSE  
 -S140-5 RETURN LINE

EXTERNAL MIX UNITS DO NOT  
 REQUIRE 2nd RETURN LINE

REV. C	
REV. B	2/15/06
REV. A	10/15/01

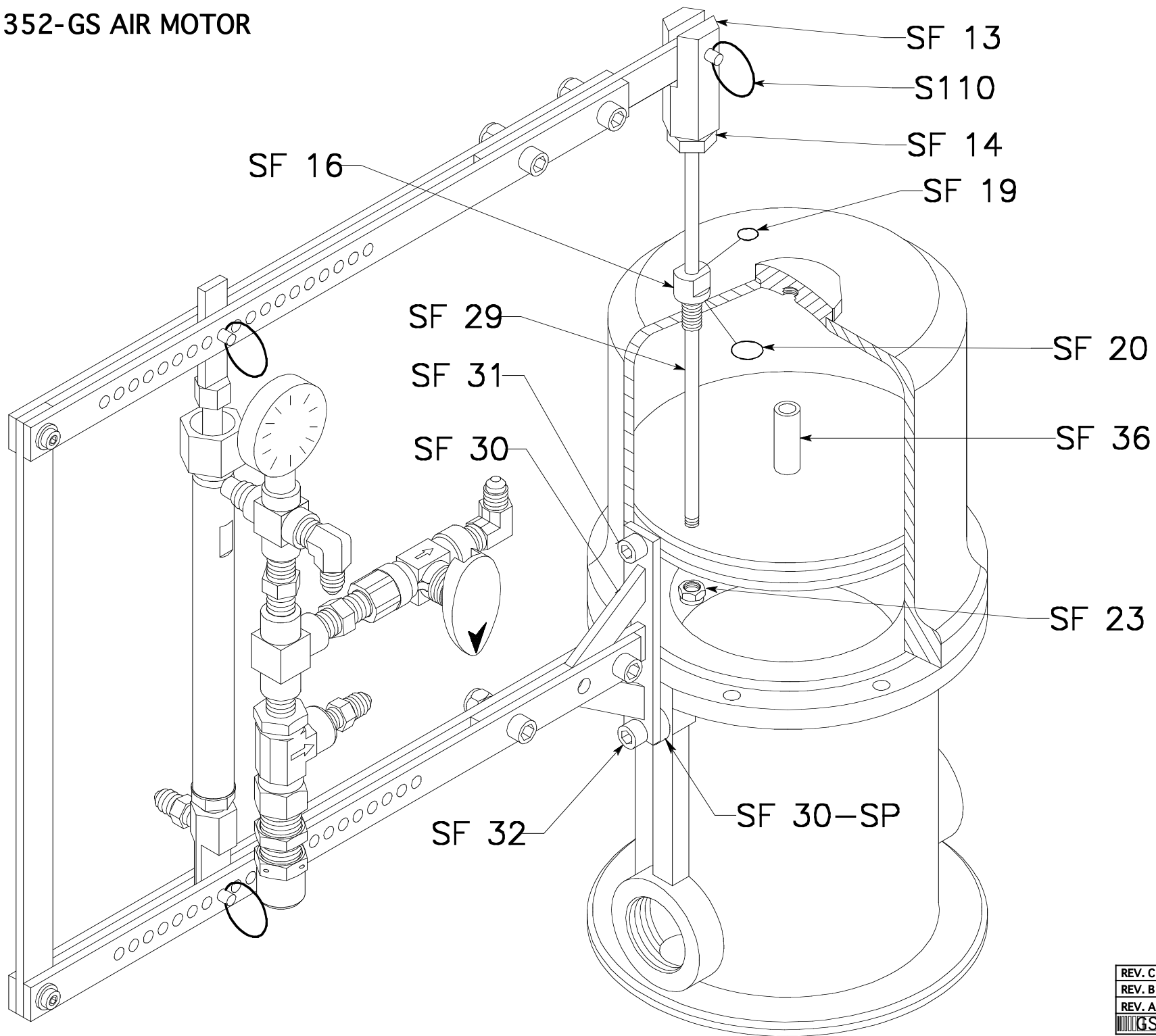
# 207-352-GS AIR MOTOR



REV. C	
REV. B	9/18/15
REV. A	9/29/09
 GS MFG	11/15/04

# S200-SLAVE ARM ASSEMBLY

15:1 AND 10:1

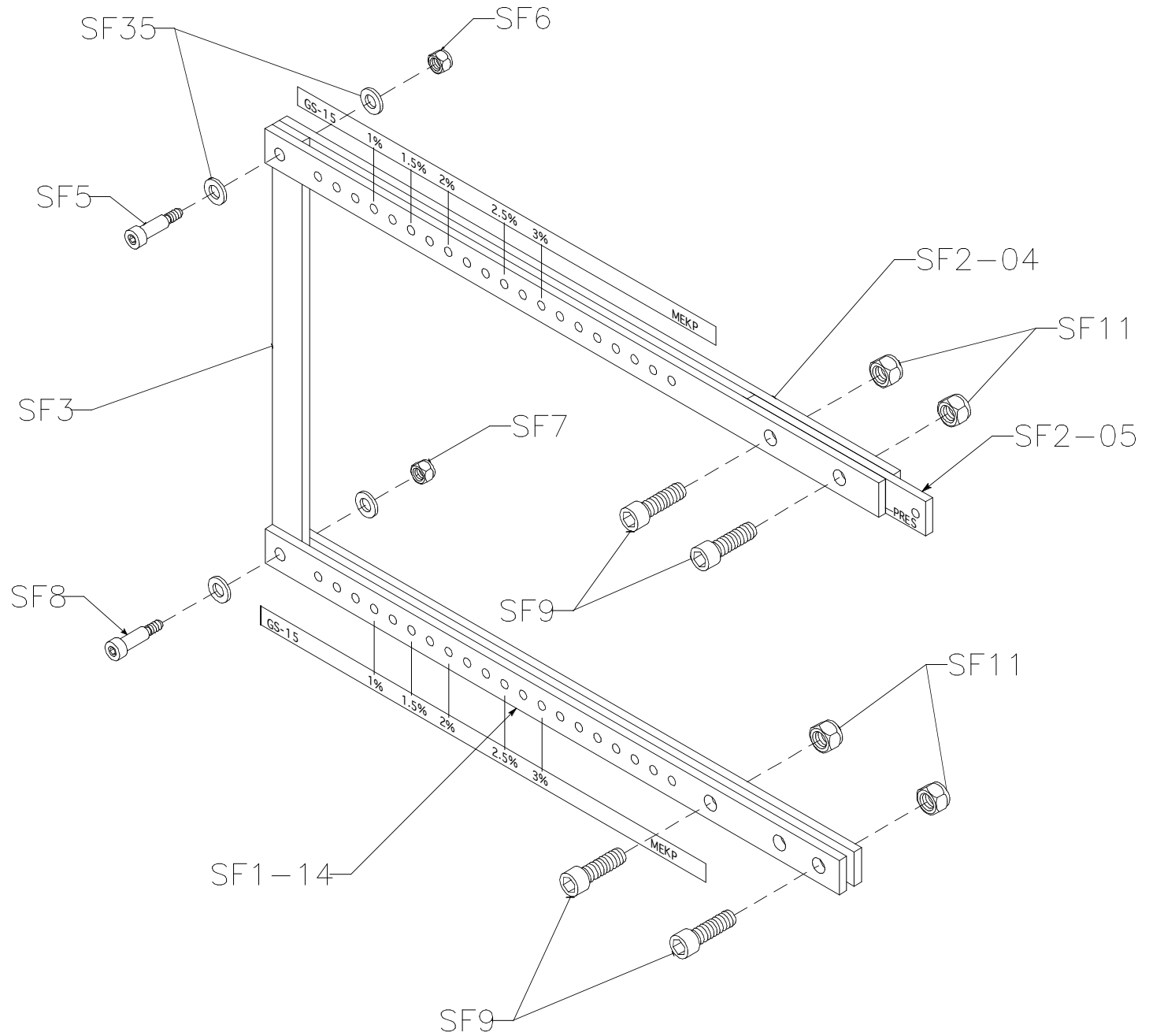

REV. C	
REV. B	12/18/05
REV. A	5 /20/03
	

# SUPER FLOW RESIN PUMP ASSEMBLIES (EXTERNAL MIX)

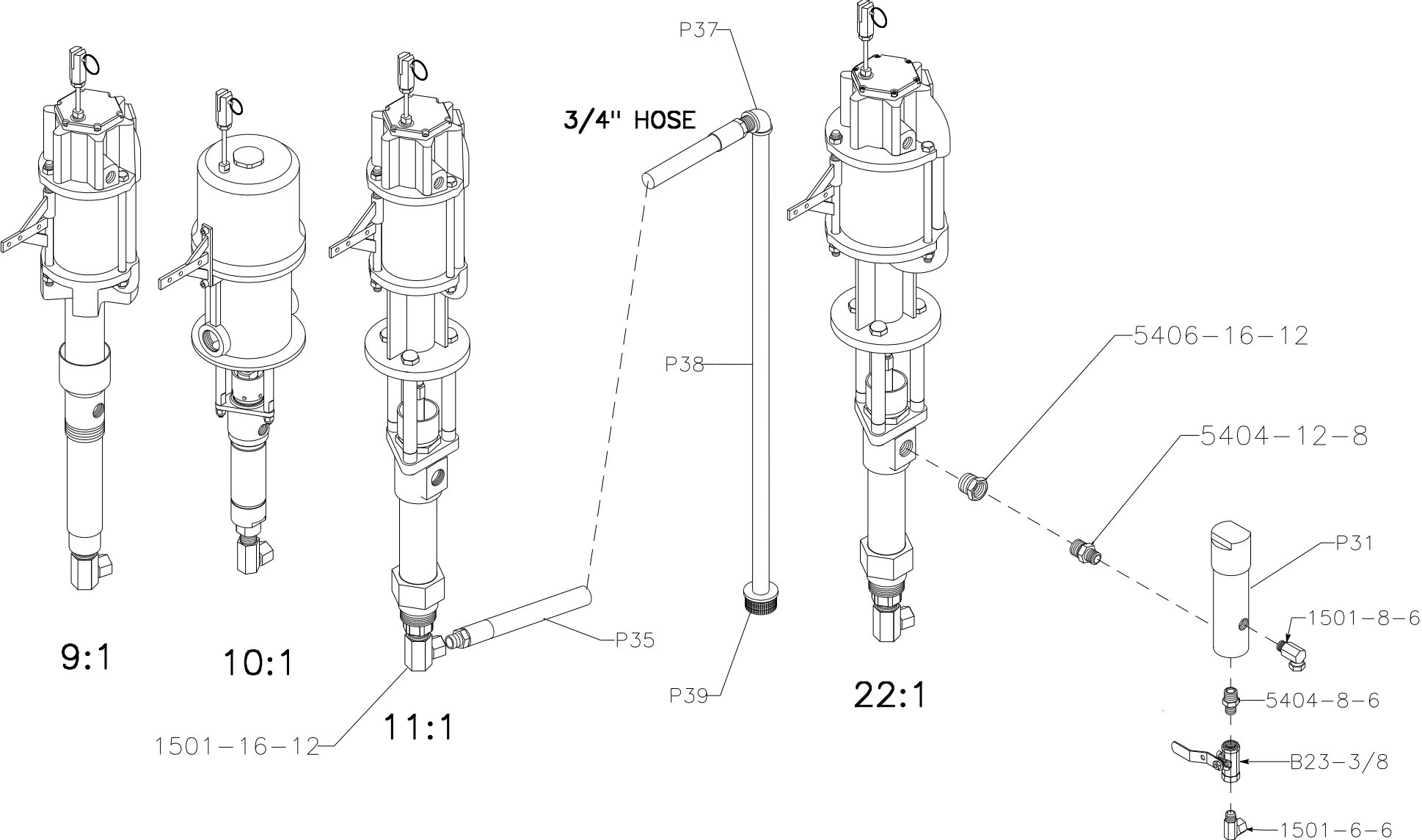

REV. C	3 / 5 / 14
REV. B	10 / 27 / 09
REV. A	2 / 9 / 07
 MFG	6 / 24 / 03

# SUPERFLOW RESIN EXT. 10:1 PUMP ASSEMBLY

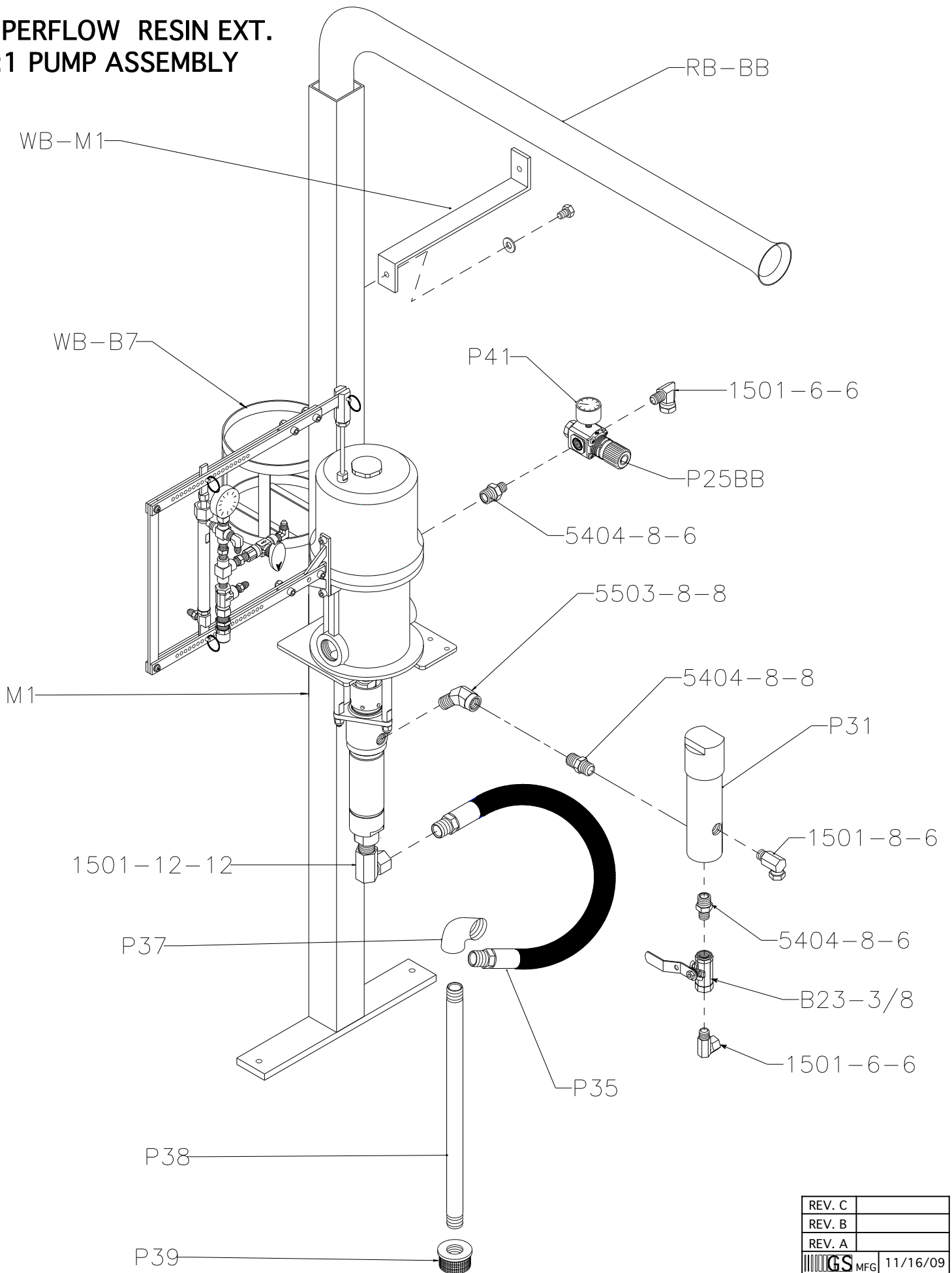

REV. C	
REV. B	
REV. A	
 MFG	11/16/09

# P31 MATERIAL FILTER

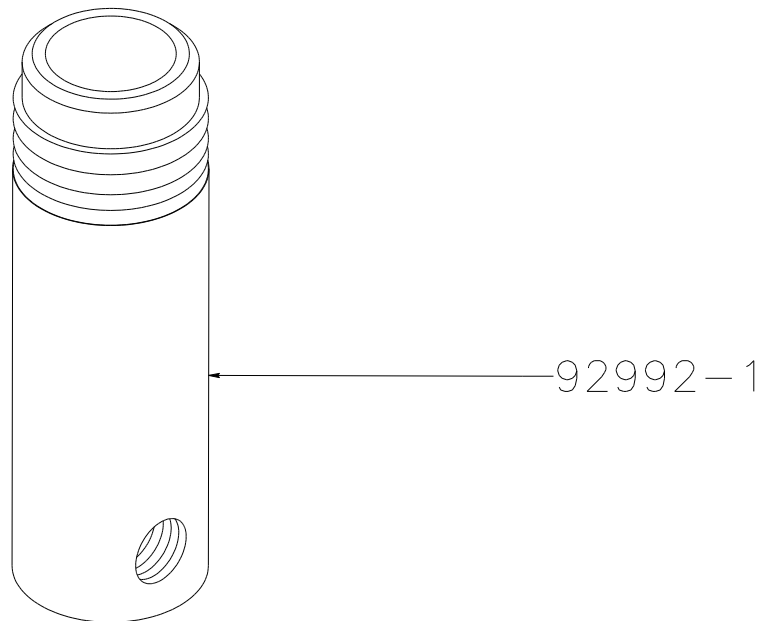

REV. C	
REV. B	7/23/13
REV. A	6/27/00
 GS MFG	7 /31/97



# M15-SF AIR MANIFOLD ASSEMBLY FOR EXTERNAL MIX

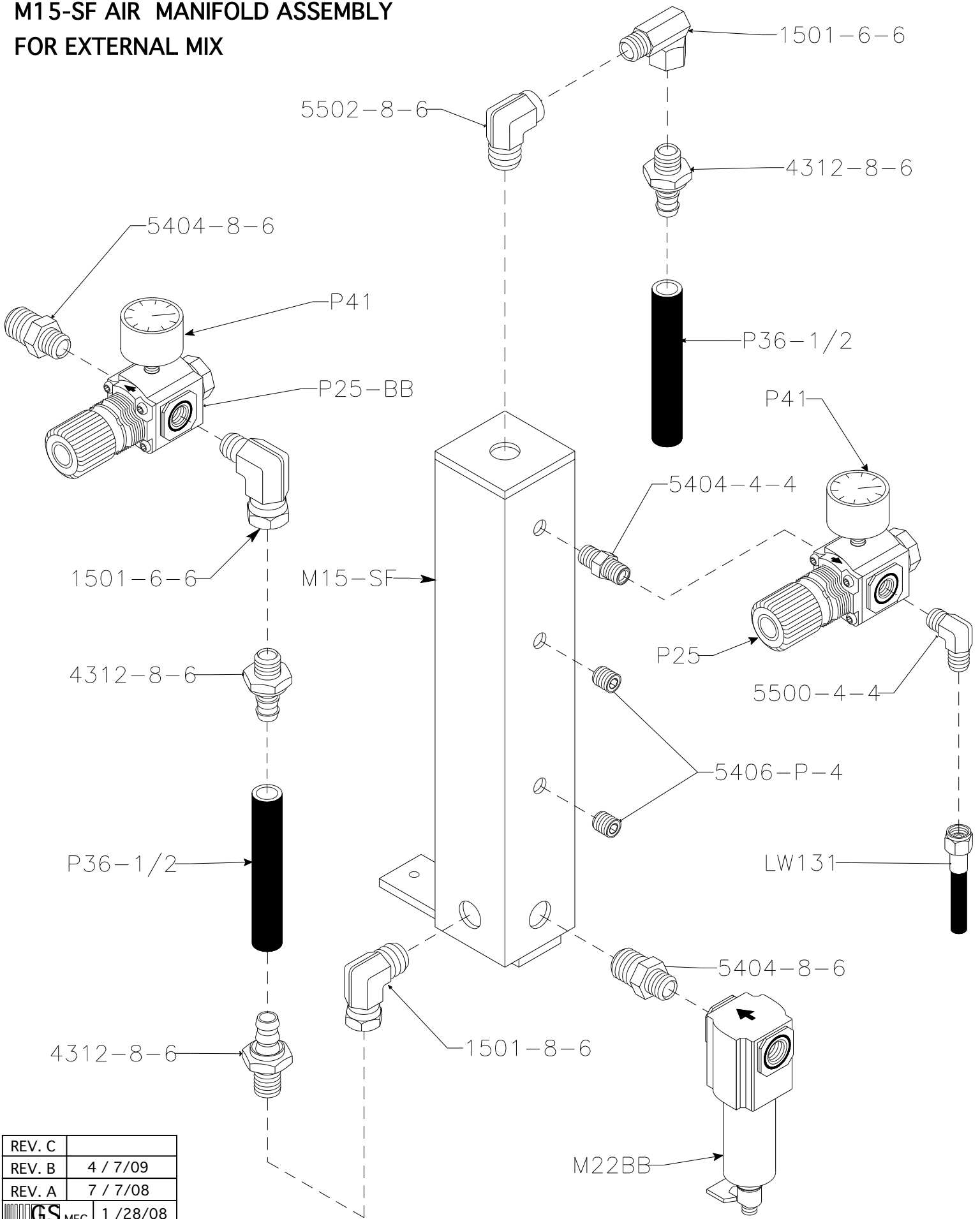

REV. C	
REV. B	4 / 7/09
REV. A	7 / 7/08
 MFG	1 / 28/08

# ROVING BRAKE-**RGB-99**

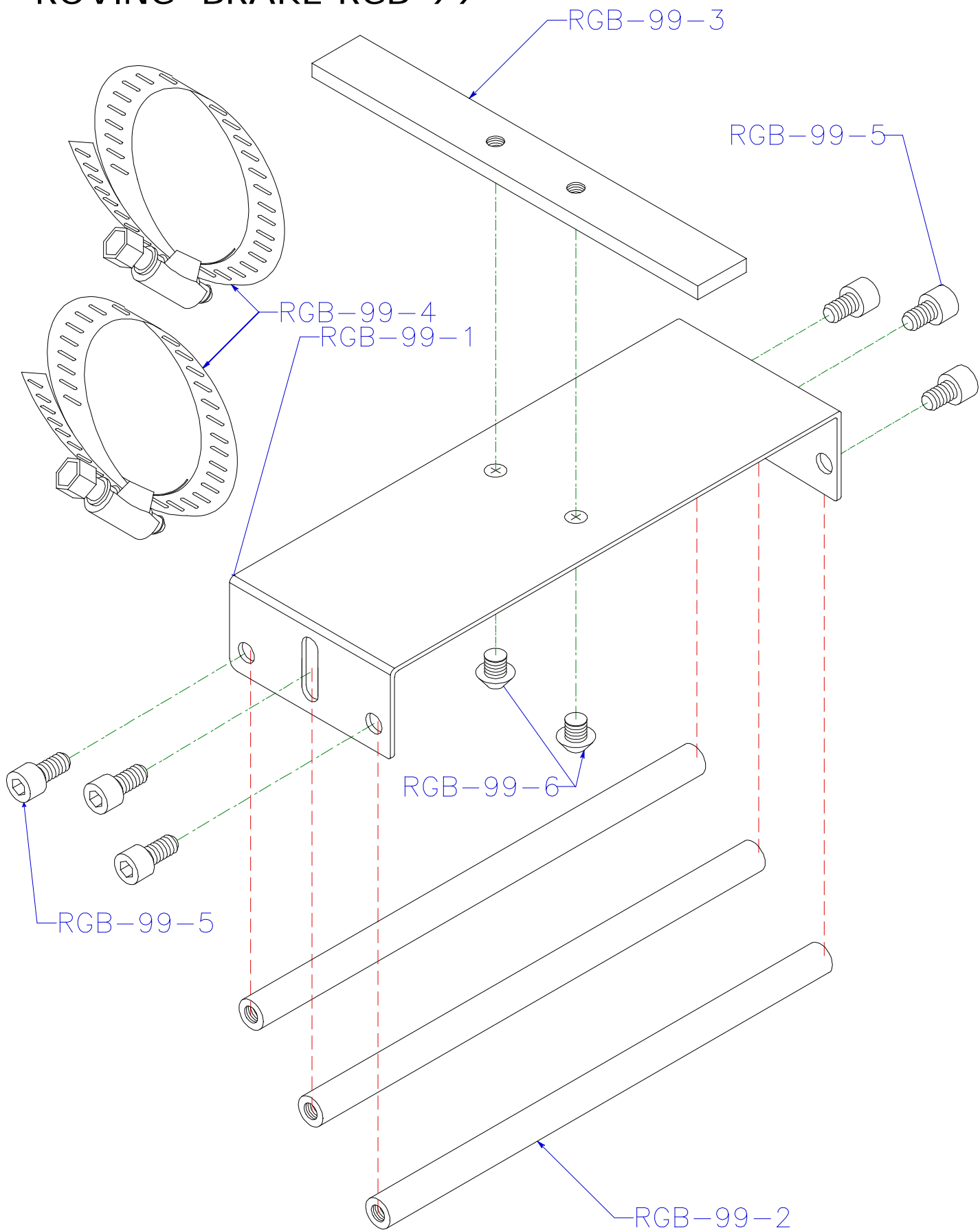

GS ROVING BRAKE- PART #- RGB-99

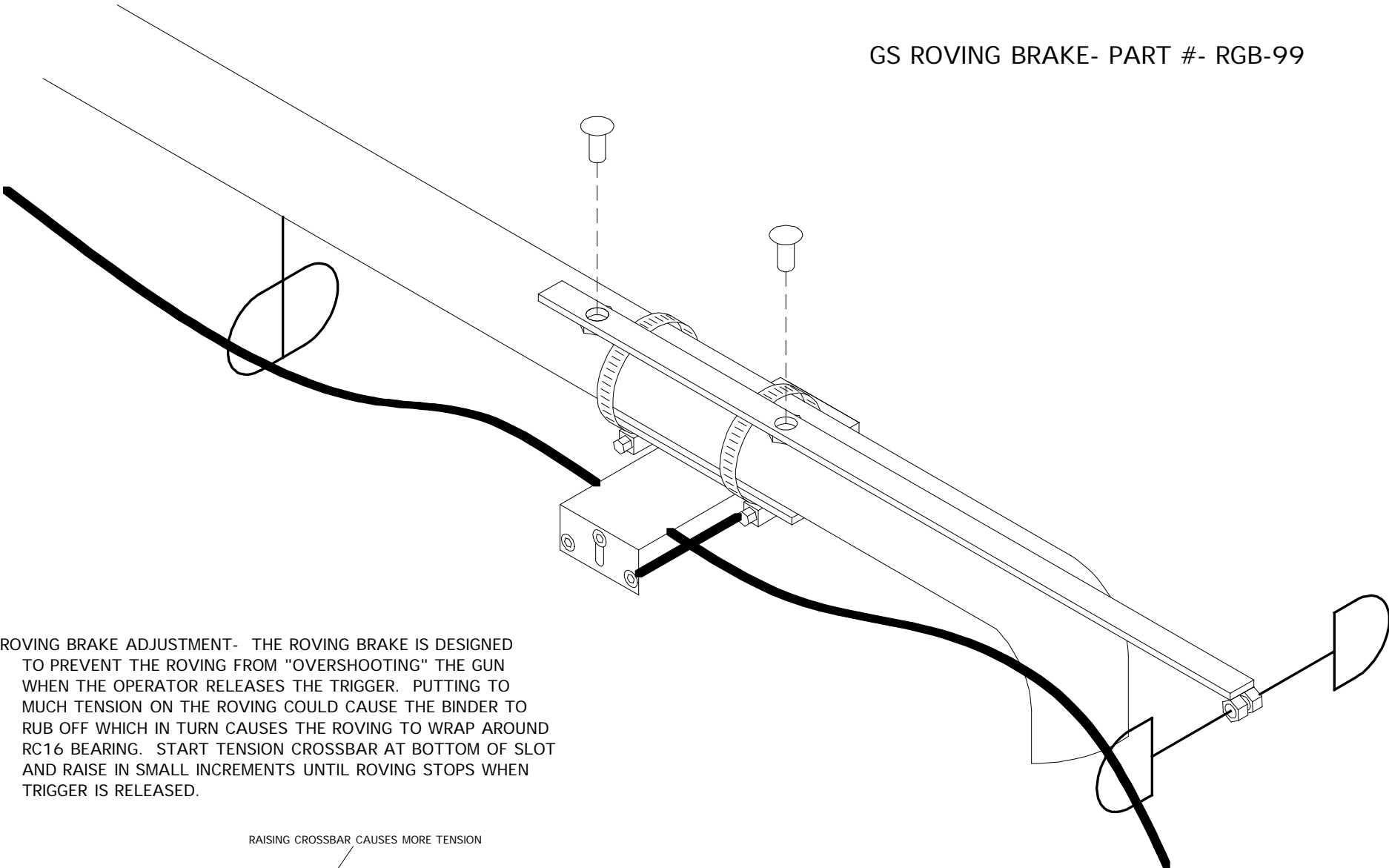

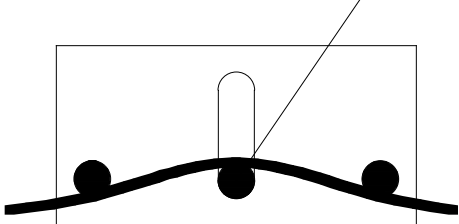

ROVING BRAKE ADJUSTMENT- THE ROVING BRAKE IS DESIGNED TO PREVENT THE ROVING FROM "OVERSHOOTING" THE GUN WHEN THE OPERATOR RELEASES THE TRIGGER. PUTTING TOO MUCH TENSION ON THE ROVING COULD CAUSE THE BINDER TO RUB OFF WHICH IN TURN CAUSES THE ROVING TO WRAP AROUND RC16 BEARING. START TENSION CROSSBAR AT BOTTOM OF SLOT AND RAISE IN SMALL INCREMENTS UNTIL ROVING STOPS WHEN TRIGGER IS RELEASED.

RAISING CROSSBAR CAUSES MORE TENSION

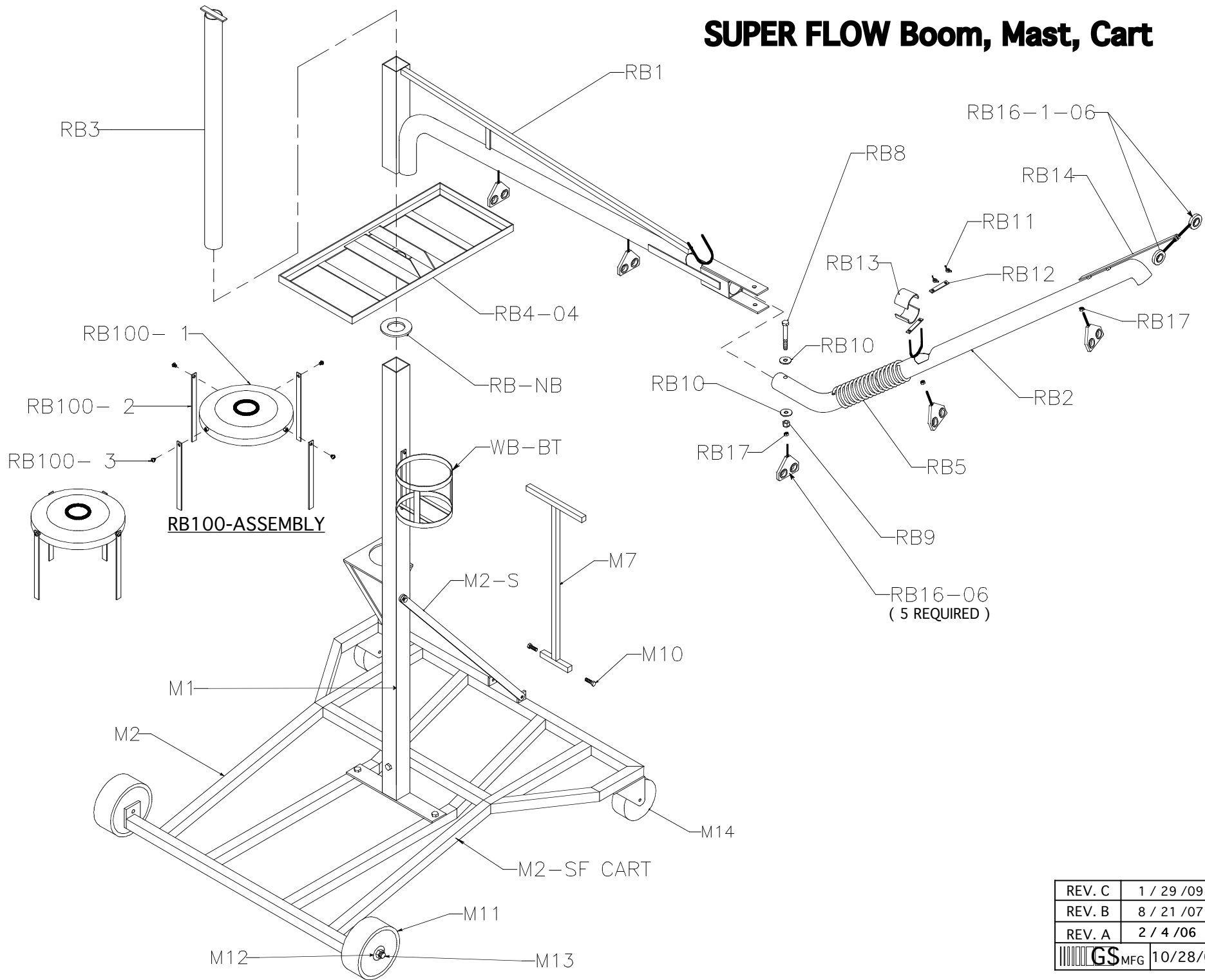

# SUPER FLOW Boom, Mast, Cart



REV. C	1 / 29 / 09
REV. B	8 / 21 / 07
REV. A	2 / 4 / 06
 GS MFG	10/28/04